



# unigy II

*Tomorrow's energy systems...today*



## Cell Specifications

- Container and Cover: Impact-Resistant Polypropylene  
28% L.O.I. (Optional)
- Separators: Microporous Glass Mat
- Safety Vent: Low Pressure, Self-Sealing
- Life: 20 Years in Float Applications—77°F (25°C)
- Float Voltage: 2.25 ± 1% Volts per Cell  
(Temperature Compensated)
- Self-Discharge: <2% Per Month
- Terminals: Lead Plated Solid Copper
- Intercell Connectors: Plated Solid Copper
- Positive Plate: 99.2% Pure Lead, 0.8% Tin
- Negative Plate: Lead Calcium



Made in U.S.A.

## Standards

Battery design and construction meet the requirements in UL 924, file number MH17218.

## Quality Assurance

Cells are manufactured to the standards and procedures of East Penn's Total Quality Assurance Program, which is derived from ISO9001 and Ford Motor Company's Q-1 System. East Penn is a Ford Q-1 certified supplier.

## Cell Construction

### A. Grids

The alloys used in the grids are: positive plate—99.2% pure lead with a 0.8% trace of tin for hardening purposes, and negative plate—a lead-calcium alloy.

### B. Tank Formation

The plates are initially charged using a tank formation procedure, which is unique in U.S. manufacturing. This procedure ensures full and uniform plate charging. Although it is more expensive than the jar formation process used by other U.S. manufacturers of valve regulated batteries, it results in batteries that provide 100% of rated capacity upon shipment. In addition, all cells are voltage matched in this formation process, guaranteeing uniform voltage.

### C. Plate Growth Provision

Positive plates are constructed from a lead-tin alloy, which exhibits slower plate growth than calcium alloys. Despite this advantage, East Penn also installs a collapsible element support beneath the plate groups in the bottom of the cell to accommodate plate expansion as the battery ages. When the plates expand vertically, the support collapses at a controlled rate, allowing expansion without damage to plates, covers, jar to-cover seal, or post seals. In addition, this element support helps prevent shock damage to the cell during transport and installation.

### D. Posts

The cell terminals are solid copper with lead plating and are designed for maximum conductivity. They have the largest connector-to-post surface area of any valve-regulated battery in the industry, which simplifies cell voltage checks. Cells with up to 15 plates have two posts, cells with 17 to 27 plates have four posts, and cells with 29 to 33 plates have six posts.

### E. Post Seals

Our new Epox-z™ post seals have been tested to 176°F (80°C) for 1000 hours to guarantee seal integrity against leaks. The post seals are color coded for safety.

### F. Jars and Covers

The jars and covers are made of a high-impact resistant polypropylene.

### G. Jar-To-Cover Seal

The cover is heat-bonded to the jar. A two-cycle jar-to-cover seal is applied. The jar and cover undergo a bead compression process. This forms a double barrier against jar to-cover leaks. Tests are conducted on 100% of the seals by submerging the cells in liquid and applying internal pressure to the cells.

### H. Valve

The safety valve opens when the cell's internal pressure reaches a level of  $4 \pm 1$  PSI. The valve has a flame arrestor to prevent the possibility of external sparks entering the cell.

## Module Features

A. Open spaces allow the middle cells to be cooled by convection, preventing the damage and short life caused by cells operating at unequal temperatures.

B. Design allows the modules to be stacked and connected by only four bolts, for quick and safe battery installation.

C. Mounting bases are high enough to allow easy installation of anchor bolts with standard equipment.

D. Seismic Zone 4 modules are standard.

E. The modules are coated and protected with a thick layer of powdered epoxy.

F. The cell terminal and inter-connection hardware are protected by a clear flame-retardant plastic cover which mounts in four places on the module, for easy installation and removal.

G. Modules for 23" equipment rack installations are also available.

## Flame-Retardant

Standard products are constructed in polypropylene - UL 94 V-O/28% L.O.I. jars and covers are optional.

## Battery Life

The design life for the Unigy II battery is 20 years in float applications at 77°F (25°C).

## New Battery Performance

All Unigy II cells perform at 100% rated capacity upon shipment. This benefit is a result of East Penn's unique tank formation process of plate activation and the repeated cycling of plates in the final formation process. Although IEEE standards allow for new lead-acid batteries to be accepted at 90% of rated capacity, Unigy II batteries deliver full rated capacity (@ 8-hour rate) at installation.

## Float Voltage Matching Cells

Cells are checked for float voltage consistency in the acceptance procedure. Any cell that does not float at a voltage within  $\pm 0.05$  volts of the voltage average will be rejected. All test data is available upon request.

## Battery Stabilization

Battery stabilization requires a very short amount of time because of the tank formation process of forming plates. East Penn's unique activation process guarantees the proper amount of acid in each cell. Voltage stabilization should be reached in a matter of days after initiation of float charge.

## Recombination Efficiency

The recombination efficiency is greater than 99% after stabilization is reached.

## Self Discharge Rate

The self discharge rate at 77°F (25°C) is <2% per month.

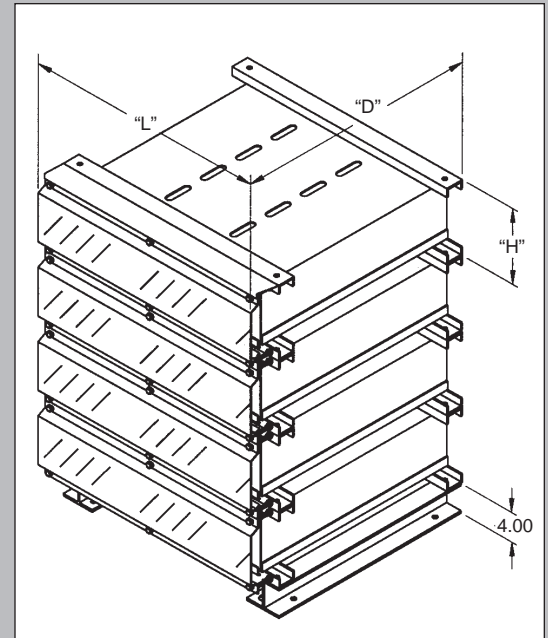
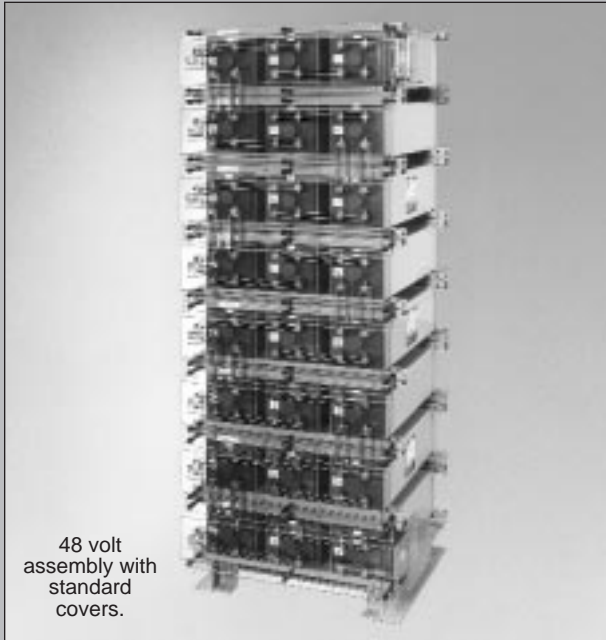

No. of Cells per Module	No. Pits.	L	H	45 Amps per Positive		75 Amps per Positive		85 Amps per Positive	
				D*	Wt.	D*	Wt.	D*	Wt.
6	5	20.19 512.8	8.50 215.9	17.50 444.5	179 81.19	24.50 622.3	259 117.48	—	—
	7	24.62 625.4	8.50 215.9	17.50 444.5	225 102.06	24.50 622.3	330 149.69	27.12 688.9	357 161.94
	9	29.12 739.7	8.50 215.9	17.50 444.5	271 122.93	24.50 622.3	397 180.08	27.12 688.9	439 199.13
	11	33.62 853.9	8.50 215.9	17.50 444.5	317 143.79	24.50 622.3	471 213.65	27.12 688.9	521 236.33
	13	38.12 968.3	8.50 215.9	17.50 444.5	362 164.20	24.50 622.3	542 245.85	27.12 688.9	603 273.52
	15	42.62 1082.6	8.56 217.5	17.50 444.5	408 185.07	24.50 622.3	612 277.60	27.12 688.9	682 309.36
3	17	27.62 701.6	8.56 217.5	—	—	24.50 622.3	382 173.28	27.12 688.9	428 194.14
	19	29.88 758.9	8.56 217.5	—	—	24.50 622.3	420 190.51	27.12 688.9	472 214.10
	21	32.10 815.8	8.56 217.5	—	—	24.50 622.3	458 207.75	27.12 688.9	508 230.43
	23	34.38 873.3	8.56 217.5	—	—	24.50 622.3	496 224.99	27.12 688.9	557 252.66
	25	36.62 930.2	8.56 217.5	—	—	24.50 622.3	530 240.41	27.12 688.9	598 271.25
	27	38.88 987.6	8.56 217.5	—	—	24.50 622.3	568 257.65	27.12 688.9	639 289.85
	29	41.12 1044.5	8.56 217.5	—	—	24.50 622.3	606 274.88	27.12 688.9	683 309.81
	31	43.38 1101.9	8.56 217.5	—	—	24.50 622.3	634 287.58	27.12 688.9	724 328.41
1	33	45.62 1158.8	8.56 217.5	—	—	24.50 622.3	681 308.90	27.12 688.9	770 349.27
	39	23.12 587.2	8.56 217.5	—	—	—	—	27.12 688.9	320 145.15
	45	25.38 644.7	8.56 217.5	—	—	—	—	27.12 688.9	375 170.10
	51	27.62 701.6	8.56 217.5	—	—	—	—	27.12 688.9	428 194.14
	57	29.88 758.9	8.56 217.5	—	—	—	—	27.12 688.9	472 214.10
	63	32.12 815.9	8.56 217.5	—	—	—	—	27.12 688.9	508 230.43
	69	34.38 873.3	8.56 217.5	—	—	—	—	27.12 688.9	557 252.66
	75	36.62 930.2	8.56 217.5	—	—	—	—	27.12 688.9	598 271.25
	81	38.88 987.6	8.56 217.5	—	—	—	—	27.12 688.9	639 289.85
	87	41.12 1044.5	8.56 217.5	—	—	—	—	27.12 688.9	683 309.81
	93	43.38 1101.9	8.56 217.5	—	—	—	—	27.12 688.9	724 328.41
	99	45.62 1158.8	8.56 217.5	—	—	—	—	27.12 688.9	770 349.27

Chart contains dimensions in inches over millimeters and weight in pounds over kilograms.  
\* Over insulation shield.

*Look into UNIGY II and Discover Today's Best Valve-Regulated Battery*

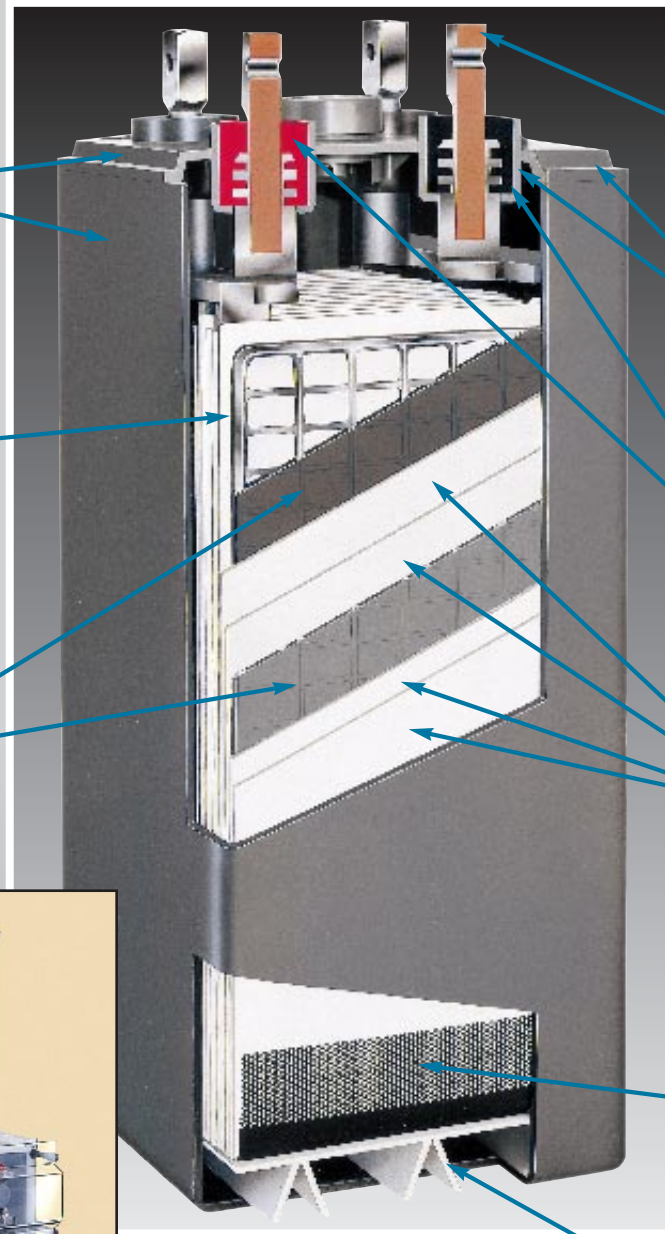

**Polypropylene Cover and Jar (28% L.O.I. Optional)**

**Pure Lead Positive Grid Alloy (99.2%)**

**Tank-Formed Plates (All cells shipped at 100% capacity.)**

**Copper Posts with Large Contact Area**

**All Seals 100% Air and Water Tested**

**Epox-Z™ Post Seal Tested to 176°F (80°C)**

**Hovosorb® II Glass Mat Separators**

**Tear Guard**

**Collapsible Bottom Bridge**



The Unigy II cells are available in modules designed for installation in 23" equipment racks. Three, four, and six cell modules ranging from 140 to 615 A.H. can be used in the rack or free standing if required. Drawings showing exact layouts and dimensions are available. Contact East Penn for details.



## UNIGY II Discharge Rates in Amperes to 1.75 VPC Final @ 77°F (25°C)

CELL TYPE	Nom. A.H. Cap. (8 Hr. Discharge Rate)	Hours									
		24	12	10	8	6	5	4	3	2	1
<b>45AH</b>											
6AVR45-5	90	5	8	10	11	14	16	19	24	32	52
6AVR45-7	140	7	13	14	17	22	25	29	36	47	78
6AVR45-9	185	9	17	19	23	29	33	39	48	63	105
6AVR45-11	230	11	21	24	29	36	41	48	60	79	131
6AVR45-13	275	14	25	29	34	43	49	58	71	95	157
6AVR45-15	320	16	29	34	40	50	58	68	83	110	183
<b>75AH</b>											
6AVR75-5	160	8	14	16	20	25	28	33	41	54	80
6AVR75-7	235	12	21	25	29	37	42	50	61	80	121
6AVR75-9	310	16	28	33	39	49	56	66	82	107	162
6AVR75-11	390	20	35	41	49	61	70	83	102	134	220
6AVR75-13	470	23	42	49	59	73	84	100	123	161	242
6AVR75-15	550	27	50	57	69	86	98	116	143	187	283
3AVR75-17	630	31	57	66	79	98	112	133	163	214	323
3AVR75-19	705	35	64	74	88	110	127	150	184	241	364
3AVR75-21	785	39	71	82	98	122	141	166	204	268	404
3AVR75-23	865	43	78	90	108	135	155	183	225	295	444
3AVR75-25	945	47	85	98	118	147	169	200	245	321	485
3AVR75-27	1025	51	92	107	128	159	183	216	265	348	525
3AVR75-29	1100	55	99	115	138	171	197	233	286	375	554
3AVR75-31	1175	59	106	123	147	184	211	250	306	402	606
3AVR75-33	1255	63	113	131	157	196	225	266	327	428	664
<b>85AH</b>											
6AVR85-7	265	13	24	27	33	41	47	56	68	90	139
6AVR85-9	350	17	32	37	44	55	63	74	91	119	185
6AVR85-11	440	22	40	46	55	68	78	93	114	149	231
6AVR85-13	530	26	47	55	66	82	94	111	137	179	278
6AVR85-15	615	31	55	64	77	95	110	130	159	209	324
3AVR85-17	695	35	63	73	87	109	125	148	182	239	370
3AVR85-19	785	39	71	82	98	123	141	167	205	268	417
3AVR85-21	875	44	79	91	109	136	157	185	228	298	463
3AVR85-23	960	48	87	100	120	150	172	204	250	328	509
3AVR85-25	1050	52	95	110	131	164	188	222	273	358	555
3AVR85-27	1135	57	103	119	142	177	204	241	296	387	602
3AVR85-29	1225	61	111	128	153	191	219	259	319	417	648
3AVR85-31	1310	65	118	137	164	204	235	278	341	447	694
3AVR85-33	1400	70	126	146	175	218	250	296	364	477	740
1AVR85-39	1585	78	142	164	197	245	282	333	410	536	833
1AVR85-45	1845	92	166	192	230	286	329	389	478	626	972
1AVR85-51	2095	105	189	219	262	327	376	444	546	715	1111
1AVR85-57	2360	118	213	247	295	368	423	500	615	804	1250
1AVR85-63	2625	131	237	274	328	409	470	555	683	894	1388
1AVR85-69	2890	144	260	301	361	449	517	611	751	983	1527
1AVR85-75	3145	157	284	329	393	490	564	666	819	1073	1666
1AVR85-81	3405	170	308	356	426	531	611	722	888	1162	1805
1AVR85-87	3675	183	332	383	459	572	658	777	956	1251	1944
1AVR85-93	3935	196	355	411	492	613	705	833	1024	1341	2083
1AVR85-99	4200	209	379	438	525	654	751	888	1092	1430	2221

## UNIGY II Discharge Rates in Amperes to 1.78 VPC Final @ 77°F (25°C)

CELL TYPE	Nom. A.H. Cap.* (8 Hr. Discharge Rate)	Hours									
		24	12	10	8	6	5	4	3	2	1
<b>45AH</b>											
6AVR45-5	90	5	8	10	11	14	16	19	23	31	50
6AVR45-7	140	7	12	14	17	21	24	29	35	46	75
6AVR45-9	185	9	16	19	23	28	32	38	46	61	99
6AVR45-11	230	11	20	24	28	35	40	48	58	77	124
6AVR45-13	275	14	25	29	34	42	49	57	69	92	149
6AVR45-15	320	16	29	33	40	49	57	67	81	107	174
<b>75AH</b>											
6AVR75-5	160	8	14	16	19	23	27	31	38	51	80
6AVR75-7	235	11	20	24	28	35	40	47	58	76	120
6AVR75-9	310	15	27	31	38	47	53	63	77	101	160
6AVR75-11	390	19	34	39	47	59	67	79	96	126	200
6AVR75-13	470	22	41	47	57	70	80	94	115	151	240
6AVR75-15	550	26	48	55	66	82	94	110	135	176	280
3AVR75-17	630	30	54	63	75	94	107	126	154	201	320
3AVR75-19	705	34	61	71	85	105	120	141	173	227	360
3AVR75-21	785	37	68	79	94	117	134	157	192	252	400
3AVR75-23	865	41	75	86	104	129	147	173	212	277	440
3AVR75-25	945	45	82	94	113	140	160	188	231	302	480
3AVR75-27	1025	49	88	102	123	152	174	204	250	327	520
3AVR75-29	1100	52	95	110	132	164	187	220	269	352	560
3AVR75-31	1175	56	102	118	141	175	201	235	289	377	600
3AVR75-33	1255	60	109	126	151	187	214	251	308	402	640
<b>85AH</b>											
6AVR85-7	265	13	23	27	33	40	46	54	66	86	132
6AVR85-9	350	17	31	36	43	54	61	73	89	115	177
6AVR85-11	440	22	39	45	54	67	77	91	111	144	221
6AVR85-13	530	26	47	54	65	81	92	109	133	173	265
6AVR85-15	615	30	55	63	76	94	108	127	155	201	309
3AVR85-17	695	34	63	72	87	108	123	145	177	230	353
3AVR85-19	785	39	70	81	98	121	138	163	199	259	397
3AVR85-21	875	43	78	90	108	134	154	181	221	287	441
3AVR85-23	960	47	86	99	119	148	169	199	244	316	486
3AVR85-25	1050	52	94	108	130	161	184	217	266	345	530
3AVR85-27	1135	56	102	117	141	175	200	236	288	374	574
3AVR85-29	1225	60	109	126	152	188	215	254	310	402	618
3AVR85-31	1310	64	117	135	163	202	231	272	332	431	662
3AVR85-33	1400	69	125	144	173	215	246	290	354	460	706
1AVR85-39	1585	77	141	162	195	242	277	326	399	517	795
1AVR85-45	1845	90	164	189	228	282	323	380	465	603	927
1AVR85-51	2095	103	187	216	260	322	369	435	531	689	1059
1AVR85-57	2360	116	211	243	293	363	415	489	598	776	1192
1AVR85-63	2625	129	234	270	325	403	461	543	664	862	1324
1AVR85-69	2890	142	258	298	358	443	507	598	731	948	1457
1AVR85-75	3145	155	281	325	390	484	553	652	797	1034	1589
1AVR85-81	3405	168	305	352	423	524	600	706	864	1120	1721
1AVR85-87	3675	181	328	379	455	564	646	761	930	1206	1854
1AVR85-93	3935	193	351	406	488	604	692	815	996	1292	1986
1AVR85-99	4200	206	375	433	520	645	738	869	1063	1379	2119

\*Nominal A.H. capacity, 8 hour discharge rates are to 1.75 VPC.

## UNIGY II Discharge Rates in Amperes to 1.81 VPC Final @ 77°F (25°C)

CELL TYPE	Nom. A.H. Cap.* (8 Hr. Discharge Rate)	Hours									
		24	12	10	8	6	5	4	3	2	1
45AH											
6AVR45-5	90	5	8	9	11	14	16	19	23	30	47
6AVR45-7	140	7	12	14	17	21	24	28	34	45	71
6AVR45-9	185	9	16	19	22	28	32	37	46	60	95
6AVR45-11	230	11	20	23	28	35	40	47	57	75	119
6AVR45-13	275	13	24	28	34	42	48	56	68	90	142
6AVR45-15	320	16	28	33	39	49	56	65	80	105	166
75AH											
6AVR75-5	160	7	13	16	19	23	26	31	38	49	76
6AVR75-7	235	11	20	23	28	35	39	46	57	74	114
6AVR75-9	310	15	27	31	37	46	53	62	75	98	153
6AVR75-11	390	19	34	39	47	58	66	77	94	123	191
6AVR75-13	470	22	40	47	56	69	79	93	113	147	229
6AVR75-15	550	26	47	54	65	81	92	108	132	172	267
3AVR75-17	630	30	54	62	74	92	105	124	151	196	305
3AVR75-19	705	33	60	70	84	104	118	139	170	221	343
3AVR75-21	785	37	67	78	93	115	131	154	189	245	381
3AVR75-23	865	41	74	86	102	127	145	170	207	270	420
3AVR75-25	945	45	80	93	112	138	158	185	226	294	458
3AVR75-27	1025	48	87	101	121	150	171	201	245	319	496
3AVR75-29	1100	52	94	109	130	161	184	216	264	343	534
3AVR75-31	1175	56	101	117	140	173	197	232	283	368	572
3AVR75-33	1255	59	107	124	149	184	210	247	302	392	610
85AH											
6AVR85-7	265	13	23	27	32	40	45	53	65	85	126
6AVR85-9	350	17	31	36	43	53	60	71	87	113	168
6AVR85-11	440	21	39	45	53	66	76	89	109	141	210
6AVR85-13	530	26	47	54	64	80	91	107	131	170	252
6AVR85-15	615	30	54	63	75	93	106	124	152	198	294
3AVR85-17	695	34	62	71	85	106	121	142	174	226	336
3AVR85-19	785	38	70	80	96	119	136	160	196	254	378
3AVR85-21	875	43	78	89	107	132	151	178	218	282	420
3AVR85-23	960	47	85	98	118	146	166	195	239	311	462
3AVR85-25	1050	51	93	107	128	159	181	213	261	339	504
3AVR85-27	1135	55	101	116	139	172	196	231	283	367	546
3AVR85-29	1225	60	109	125	150	185	212	249	305	395	588
3AVR85-31	1310	64	116	134	160	199	227	266	326	423	630
3AVR85-33	1400	68	124	143	171	212	242	284	348	452	672
1AVR85-39	1585	77	140	161	192	238	272	320	392	508	756
1AVR85-45	1845	90	163	188	224	278	317	373	457	593	882
1AVR85-51	2095	102	186	214	256	318	363	426	522	677	1008
1AVR85-57	2360	115	209	241	288	358	408	479	588	762	1134
1AVR85-63	2625	128	233	268	320	397	453	533	653	847	1260
1AVR85-69	2890	141	256	295	352	437	499	586	718	931	1386
1AVR85-75	3145	153	279	321	384	477	544	639	783	1016	1512
1AVR85-81	3405	166	302	348	417	516	589	692	849	1101	1638
1AVR85-87	3675	179	326	375	449	556	635	746	914	1185	1764
1AVR85-93	3935	192	349	402	481	596	680	799	979	1270	1890
1AVR85-99	4200	205	372	429	513	636	725	852	1044	1355	2016

\*Nominal A.H. capacity, 8 hour discharge rates are to 1.75 VPC.

## UNIGY II Discharge Rates in Amperes to 1.84 VPC Final @ 77°F (25°C)

CELL TYPE	Nom. A.H. Cap.* (8 Hr. Discharge Rate)	Hours									
		24	12	10	8	6	5	4	3	2	1
<b>45AH</b>											
6AVR45-5	90	4	8	9	11	14	15	18	22	29	44
6AVR45-7	140	7	12	14	16	20	23	27	33	43	66
6AVR45-9	185	9	16	18	22	27	31	36	44	58	88
6AVR45-11	230	11	20	23	27	34	39	45	55	72	110
6AVR45-13	275	13	24	27	33	41	46	54	66	86	132
6AVR45-15	320	15	28	32	38	48	54	63	77	101	154
<b>75AH</b>											
6AVR75-5	160	7	13	15	18	23	26	30	37	48	71
6AVR75-7	235	11	20	23	27	34	39	45	55	71	106
6AVR75-9	310	15	26	30	36	45	51	60	73	95	142
6AVR75-11	390	18	33	38	45	56	64	75	91	119	177
6AVR75-13	470	22	39	46	54	68	77	90	110	143	213
6AVR75-15	550	26	46	53	63	79	90	105	128	166	248
3AVR75-17	630	29	53	61	72	90	103	120	146	190	283
3AVR75-19	705	33	59	68	82	101	116	135	165	214	319
3AVR75-21	785	36	66	76	91	112	129	150	183	237	354
3AVR75-23	865	40	72	84	100	124	141	165	201	261	390
3AVR75-25	945	44	79	91	109	135	154	180	219	285	425
3AVR75-27	1025	47	85	99	118	146	167	195	238	309	461
3AVR75-29	1100	51	92	106	127	157	180	210	256	332	496
3AVR75-31	1175	55	99	114	136	169	193	225	274	356	531
3AVR75-33	1255	58	105	122	145	180	206	240	293	380	567
<b>85AH</b>											
6AVR85-7	265	13	23	26	31	39	44	52	63	81	120
6AVR85-9	350	17	30	35	42	52	59	69	84	109	160
6AVR85-11	440	21	38	44	52	65	74	86	105	136	200
6AVR85-13	530	25	45	52	62	78	88	104	126	163	240
6AVR85-15	615	29	53	61	73	90	103	121	147	190	280
3AVR85-17	695	34	60	70	83	103	118	138	168	217	320
3AVR85-19	785	38	68	79	94	116	133	155	189	244	360
3AVR85-21	875	42	76	87	104	129	147	173	210	271	400
3AVR85-23	960	46	83	96	114	142	162	190	231	298	440
3AVR85-25	1050	50	91	105	125	155	177	207	252	325	480
3AVR85-27	1135	55	98	114	135	168	192	224	273	352	520
3AVR85-29	1225	59	106	122	146	181	206	242	294	379	560
3AVR85-31	1310	63	113	131	156	194	221	259	315	406	600
3AVR85-33	1400	67	121	140	166	207	236	276	336	433	640
1AVR85-39	1585	76	136	157	187	232	265	311	378	488	720
1AVR85-45	1845	88	159	183	218	271	310	362	441	569	840
1AVR85-51	2095	101	181	210	249	310	354	414	504	650	960
1AVR85-57	2360	113	204	236	281	349	398	466	567	731	1080
1AVR85-63	2625	126	226	262	312	387	442	518	630	812	1200
1AVR85-69	2890	138	249	288	343	426	486	569	693	894	1320
1AVR85-75	3145	151	272	314	374	465	531	621	756	975	1440
1AVR85-81	3405	164	294	340	405	503	575	673	819	1056	1560
1AVR85-87	3675	176	317	367	437	542	619	725	882	1137	1680
1AVR85-93	3935	189	340	393	468	581	663	776	945	1218	1800
1AVR85-99	4200	201	362	419	499	620	708	828	1008	1300	1920

\*Nominal A.H. capacity, 8 hour discharge rates are to 1.75 VPC.



## UNIGY II Discharge Rates in Amperes to 1.88 VPC Final @ 77°F (25°C)

CELL TYPE	Nom. A.H. Cap.* (8 Hr. Discharge Rate)	Hours									
		24	12	10	8	6	5	4	3	2	1
<b>45AH</b>											
6AVR45-5	90	4	8	9	10	13	15	17	21	28	41
6AVR45-7	140	6	12	13	16	19	22	26	31	41	62
6AVR45-9	185	8	15	18	21	26	29	34	42	55	82
6AVR45-11	230	11	19	22	26	32	37	43	52	68	103
6AVR45-13	275	13	23	26	31	39	44	52	62	82	123
6AVR45-15	320	15	27	31	37	45	51	60	73	96	144
<b>75AH</b>											
6AVR75-5	160	7	13	15	17	22	24	29	34	44	66
6AVR75-7	235	11	19	22	26	32	37	43	51	66	99
6AVR75-9	310	14	25	29	35	43	49	57	69	88	132
6AVR75-11	390	18	32	36	43	54	61	71	86	110	165
6AVR75-13	470	21	38	44	52	65	73	85	103	132	198
6AVR75-15	550	25	44	51	61	75	86	100	120	154	231
3AVR75-17	630	28	50	58	69	86	98	114	137	176	264
3AVR75-19	705	32	57	65	78	97	110	128	154	198	297
3AVR75-21	785	35	63	73	87	107	122	142	171	220	330
3AVR75-23	865	39	69	80	95	118	135	156	189	241	363
3AVR75-25	945	42	76	87	104	129	147	171	206	263	396
3AVR75-27	1025	46	82	95	113	140	159	185	223	285	429
3AVR75-29	1100	49	88	102	121	150	171	199	240	307	462
3AVR75-31	1175	53	95	109	130	161	183	213	257	329	495
3AVR75-33	1255	56	101	116	139	172	196	228	274	351	528
<b>85AH</b>											
6AVR85-7	265	12	22	25	30	37	42	49	59	75	107
6AVR85-9	350	16	29	33	40	49	56	66	79	100	143
6AVR85-11	440	20	36	42	50	62	70	82	98	125	179
6AVR85-13	530	24	43	50	60	74	84	98	118	150	214
6AVR85-15	615	28	51	59	70	86	98	115	138	175	250
3AVR85-17	695	32	58	67	79	99	112	131	157	200	286
3AVR85-19	785	36	65	75	89	111	126	147	177	225	321
3AVR85-21	875	40	72	84	99	123	140	164	197	250	357
3AVR85-23	960	44	80	92	109	136	154	180	216	275	393
3AVR85-25	1050	48	87	100	119	148	168	196	236	300	429
3AVR85-27	1135	52	94	109	129	160	182	213	256	325	464
3AVR85-29	1225	56	101	117	139	173	196	229	275	350	500
3AVR85-31	1310	60	108	125	149	185	210	245	295	375	536
3AVR85-33	1400	64	116	134	159	197	224	262	315	400	571
1AVR85-39	1585	72	130	150	179	222	253	295	354	450	643
1AVR85-45	1845	84	152	176	209	259	295	344	413	525	750
1AVR85-51	2095	96	173	201	238	296	337	393	472	600	857
1AVR85-57	2360	109	195	226	268	333	379	442	531	675	964
1AVR85-63	2625	121	217	251	298	370	421	491	590	750	1071
1AVR85-69	2890	133	238	276	328	407	463	540	649	825	1178
1AVR85-75	3145	145	260	301	357	444	505	589	708	900	1286
1AVR85-81	3405	157	282	326	387	481	547	638	767	975	1393
1AVR85-87	3675	169	304	351	417	518	589	687	826	1050	1500
1AVR85-93	3935	181	325	376	447	555	631	736	885	1125	1607
1AVR85-99	4200	193	347	401	477	592	673	785	944	1200	1714

\*Nominal A.H. capacity, 8 hour discharge rates are to 1.75 VPC.

## UNIGY II Discharge Rates in Amperes to 1.90 VPC Final @ 77°F (25°C)

CELL TYPE	Nom. A.H. Cap.* (8 Hr. Discharge Rate)	Hours									
		24	12	10	8	6	5	4	3	2	1
<b>45AH</b>											
6AVR45-5	90	4	7	8	10	12	14	16	20	26	37
6AVR45-7	140	6	11	13	15	18	21	24	29	38	56
6AVR45-9	185	8	15	17	20	25	28	32	39	51	74
6AVR45-11	230	10	18	21	25	31	35	40	49	64	93
6AVR45-13	275	12	22	25	30	37	41	49	59	77	111
6AVR45-15	320	14	25	29	35	43	48	57	68	89	130
<b>75AH</b>											
6AVR75-5	160	7	12	14	17	21	23	27	32	41	59
6AVR75-7	235	10	18	21	25	31	35	41	48	62	88
6AVR75-9	310	14	24	28	33	41	47	54	65	82	118
6AVR75-11	390	17	31	35	42	52	58	68	81	102	147
6AVR75-13	470	20	37	42	50	62	70	81	97	123	177
6AVR75-15	550	24	43	49	58	72	82	95	113	143	206
3AVR75-17	630	27	49	56	67	83	93	108	129	164	235
3AVR75-19	705	31	55	63	75	93	105	122	145	184	265
3AVR75-21	785	34	61	70	83	103	117	135	161	205	294
3AVR75-23	865	38	67	77	92	113	128	149	178	225	324
3AVR75-25	945	41	73	84	100	124	140	162	194	245	353
3AVR75-27	1025	44	79	91	108	134	152	176	210	266	383
3AVR75-29	1100	48	86	98	117	144	163	189	226	286	412
3AVR75-31	1175	51	92	105	125	155	175	203	242	307	441
3AVR75-33	1255	55	98	112	133	165	186	216	258	327	471
<b>85AH</b>											
6AVR85-7	265	12	21	24	29	36	40	46	55	69	97
6AVR85-9	350	16	28	32	38	47	53	62	74	93	129
6AVR85-11	440	20	35	40	48	59	67	77	92	116	161
6AVR85-13	530	23	42	48	57	71	80	93	110	139	194
6AVR85-15	615	27	49	57	67	83	94	108	129	162	226
3AVR85-17	695	31	56	65	76	95	107	124	147	185	258
3AVR85-19	785	35	63	73	86	107	120	139	165	208	291
3AVR85-21	875	39	70	81	96	118	134	154	184	231	323
3AVR85-23	960	43	77	89	105	130	147	170	202	254	355
3AVR85-25	1050	47	84	97	115	142	160	185	221	277	387
3AVR85-27	1135	51	91	105	124	154	174	201	239	300	420
3AVR85-29	1225	55	98	113	134	166	187	216	257	323	452
3AVR85-31	1310	59	105	121	143	178	201	232	276	346	484
3AVR85-33	1400	62	112	129	153	189	214	247	294	369	516
1AVR85-39	1585	70	126	145	172	213	241	278	331	416	581
1AVR85-45	1845	82	147	170	201	249	281	324	386	485	678
1AVR85-51	2095	94	168	194	229	284	321	370	441	554	775
1AVR85-57	2360	105	189	218	258	320	361	417	496	623	872
1AVR85-63	2625	117	210	242	287	355	401	463	551	692	968
1AVR85-69	2890	129	231	266	315	391	441	509	607	762	1065
1AVR85-75	3145	140	252	291	344	426	481	556	662	831	1162
1AVR85-81	3405	152	273	315	373	462	522	602	717	900	1259
1AVR85-87	3675	164	295	339	401	497	562	648	772	969	1356
1AVR85-93	3935	175	316	363	430	533	602	694	827	1038	1453
1AVR85-99	4200	187	337	387	459	568	642	741	882	1108	1549

\*Nominal A.H. capacity, 8 hour discharge rates are to 1.75 VPC.

## UNIGY II Discharge Rates in Amperes to 1.94 VPC Final @ 77°F (25°C)

CELL TYPE	Nom. A.H. Cap.* (8 Hr. Discharge Rate)	Hours									
		24	12	10	8	6	5	4	3	2	1
<b>45AH</b>											
6AVR45-5	90	4	7	8	9	11	13	15	18	23	33
6AVR45-7	140	6	10	11	13	17	19	22	27	34	50
6AVR45-9	185	7	13	15	18	22	25	29	36	46	66
6AVR45-11	230	9	16	19	22	28	31	37	45	57	83
6AVR45-13	275	11	20	23	27	33	38	44	53	68	99
6AVR45-15	320	13	23	26	31	39	44	51	62	80	116
<b>75AH</b>											
6AVR75-5	160	6	11	13	15	19	21	24	29	36	52
6AVR75-7	235	9	17	19	23	28	31	36	43	54	78
6AVR75-9	310	12	22	26	30	37	42	48	57	72	104
6AVR75-11	390	16	28	32	38	47	52	60	71	90	130
6AVR75-13	470	19	33	38	45	56	63	72	86	108	156
6AVR75-15	550	22	39	45	53	65	73	84	100	126	182
3AVR75-17	630	25	44	51	60	74	84	96	114	144	208
3AVR75-19	705	28	50	58	68	84	94	108	129	162	234
3AVR75-21	785	31	56	64	75	93	105	120	143	180	260
3AVR75-23	865	34	61	70	83	102	115	132	157	198	286
3AVR75-25	945	37	67	77	90	112	126	144	171	216	312
3AVR75-27	1025	40	72	83	98	121	136	156	186	234	338
3AVR75-29	1100	43	78	89	106	130	146	168	200	252	364
3AVR75-31	1175	47	83	96	113	139	157	180	214	270	390
3AVR75-33	1255	50	89	102	121	149	167	192	229	288	416
<b>85AH</b>											
6AVR85-7	265	11	19	22	26	32	36	42	50	62	84
6AVR85-9	350	14	26	29	35	43	48	56	66	83	112
6AVR85-11	440	18	32	37	43	54	60	69	83	103	140
6AVR85-13	530	21	38	44	52	64	72	83	99	124	168
6AVR85-15	615	25	45	51	61	75	84	97	116	144	196
3AVR85-17	695	28	51	59	69	86	96	111	133	165	224
3AVR85-19	785	32	57	66	78	96	108	125	149	185	252
3AVR85-21	875	35	64	73	86	107	120	139	166	206	280
3AVR85-23	960	39	70	81	95	118	132	153	182	227	308
3AVR85-25	1050	42	76	88	104	128	144	166	199	247	336
3AVR85-27	1135	46	83	95	112	139	156	180	215	268	364
3AVR85-29	1225	49	89	103	121	150	168	194	232	288	392
3AVR85-31	1310	53	96	110	130	160	180	208	249	309	420
3AVR85-33	1400	56	102	117	138	171	192	222	265	329	448
1AVR85-39	1585	63	115	132	156	193	216	250	298	371	504
1AVR85-45	1845	74	134	154	182	225	252	291	348	432	588
1AVR85-51	2095	84	153	176	207	257	288	333	398	494	672
1AVR85-57	2360	95	172	198	233	289	324	374	447	556	756
1AVR85-63	2625	106	191	220	259	321	360	416	497	617	840
1AVR85-69	2890	116	210	242	285	353	396	457	547	679	924
1AVR85-75	3145	127	229	264	311	385	432	499	597	741	1008
1AVR85-81	3405	137	248	286	337	417	468	541	646	802	1092
1AVR85-87	3675	148	268	308	363	449	504	582	696	864	1176
1AVR85-93	3935	158	287	330	389	481	540	624	746	926	1260
1AVR85-99	4200	169	306	352	415	513	576	665	795	988	1344

\*Nominal A.H. capacity, 8 hour discharge rates are to 1.75 VPC.

## UNIGY II Discharge Rates in Watts per Cell to 1.67 VPC Final @ 77°F (25°C)

CELL TYPE	Minutes					
	5	10	15	20	30	60
<b>45AH</b>						
6AVR45-5	312	271	234	210	175	115
6AVR45-7	468	406	350	315	262	172
6AVR45-9	624	542	469	421	350	231
6AVR45-11	781	678	585	526	437	288
6AVR45-13	939	813	703	631	524	346
6AVR45-15	1093	949	819	736	612	403
<b>75 AH</b>						
6AVR75-5	362	321	288	263	225	160
6AVR75-7	542	481	432	395	338	239
6AVR75-9	723	643	577	526	450	320
6AVR75-11	903	802	720	658	564	398
6AVR75-13	1042	964	865	789	677	479
6AVR75-15	1042	1042	1009	921	789	558
3AVR75-17	1447	1285	1153	1052	901	637
3AVR75-19	1627	1445	1297	1184	1014	716
3AVR75-21	1808	1606	1442	1316	1128	796
3AVR75-23	1988	1766	1585	1447	1241	877
3AVR75-25	2084	1927	1730	1579	1353	956
3AVR75-27	2084	2084	1874	1710	1465	1035
3AVR75-29	2532	2249	2019	1842	1578	1116
3AVR75-31	2712	2408	2162	1973	1692	1195
3AVR75-33	2893	2570	2307	2105	1805	1274
<b>85 AH</b>						
6AVR85-7	621	553	498	453	364	273
6AVR85-9	828	737	664	603	485	365
6AVR85-11	1035	920	830	754	607	457
6AVR85-13	1042	1042	995	905	726	549
6AVR85-15	1042	1042	1042	1042	848	639
3AVR85-17	1657	1474	1329	1206	969	730
3AVR85-19	1864	1658	1494	1353	1090	822
3AVR85-21	2072	1842	1660	1508	1212	914
3AVR85-23	2084	2025	1827	1659	1333	1005
3AVR85-25	2084	2084	1992	1810	1455	1097
3AVR85-27	2084	2084	2084	1960	1576	1187
3AVR85-29	2900	2578	2324	2112	1698	1279
3AVR85-31	3107	2763	2491	2263	1819	1370
3AVR85-33	3126	2946	2658	2414	1939	1462

## UNIGY II Discharge Rates in Watts per Cell to 1.75 VPC Final @ 77°F (25°C)

CELL TYPE	Minutes					
	5	10	15	20	30	60
<b>45AH</b>						
6AVR45-5	269	226	197	178	144	97
6AVR45-7	403	340	296	267	215	145
6AVR45-9	538	452	394	357	288	195
6AVR45-11	673	565	493	445	359	244
6AVR45-13	807	679	592	536	432	292
6AVR45-15	942	791	690	624	503	341
<b>75 AH</b>						
6AVR75-5	354	312	280	254	215	149
6AVR75-7	529	469	420	383	325	226
6AVR75-9	707	624	560	509	433	302
6AVR75-11	884	781	700	637	540	410
6AVR75-13	1042	938	840	764	648	451
6AVR75-15	1042	1042	980	892	756	528
3AVR75-17	1413	1250	1120	1018	865	602
3AVR75-19	1590	1405	1260	1146	973	679
3AVR75-21	1767	1562	1399	1273	1080	753
3AVR75-23	1945	1719	1539	1400	1188	828
3AVR75-25	2084	1874	1679	1527	1296	904
3AVR75-27	2084	2031	1819	1655	1405	979
3AVR75-29	2474	2186	1959	1782	1513	1033
3AVR75-31	2651	2343	2099	1910	1621	1130
3AVR75-33	2828	2500	2239	2036	1728	1205
<b>85 AH</b>						
6AVR85-7	607	538	481	437	350	259
6AVR85-9	811	717	642	583	467	345
6AVR85-11	1013	897	802	729	584	431
6AVR85-13	1042	1042	961	875	701	518
6AVR85-15	1042	1042	1042	1021	818	604
3AVR85-17	1620	1434	1283	1166	934	690
3AVR85-19	1824	1614	1442	1312	1051	778
3AVR85-21	2026	1792	1604	1458	1163	864
3AVR85-23	2084	1992	1763	1605	1285	949
3AVR85-25	2084	2084	1925	1751	1402	1035
3AVR85-27	2084	2084	2084	1895	1518	1123
3AVR85-29	2837	2508	2246	2041	1635	1208
3AVR85-31	3039	2688	2406	2188	1752	1294
3AVR85-33	3126	2867	2565	2334	1869	1380



**Unigy II 45A Series 1 - 24 Hours**

**Unigy II Performance Curves**

The following graphs can be helpful in determining the ampere hour capacity and the number of amperes per positive plate for selected battery types at different end voltages from those given in Tables 1, 2 and 3.

There is one set of performance curves for the 45, 75 and 85 ampere series Unigy II batteries.

To find the ampere hour capacity at a specified end voltage, simply find the intersection of the time and end voltage curves. Multiply this value by the number of positive plates in the specified cell to obtain the cell's A.H. rating. (Note: Cells have one more negative plate than positive plate, i.e., an 3AVR75-33 has 16 positive plates and 17 negative plates.) By aligning this intersection point with the X axis, one can determine the number of amperes per positive plate delivered at the specified discharge rate.

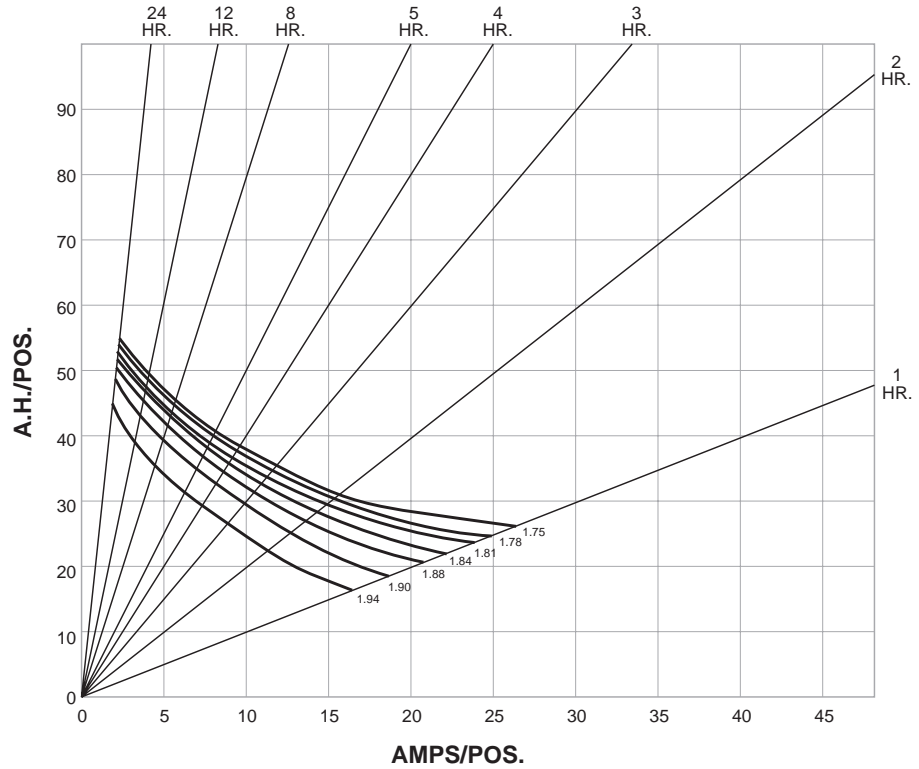

**Unigy II 75A Series 1 - 24 Hours**

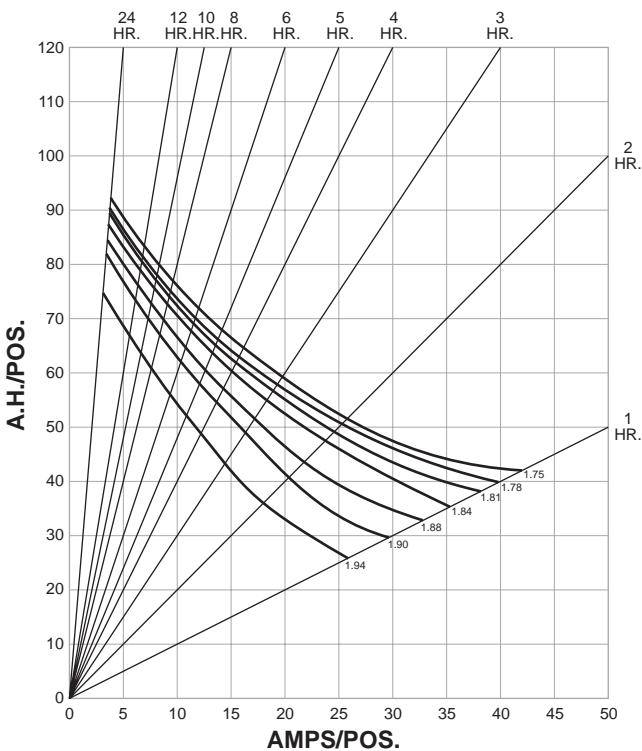

**Unigy II 85A Series 1 - 24 Hours**

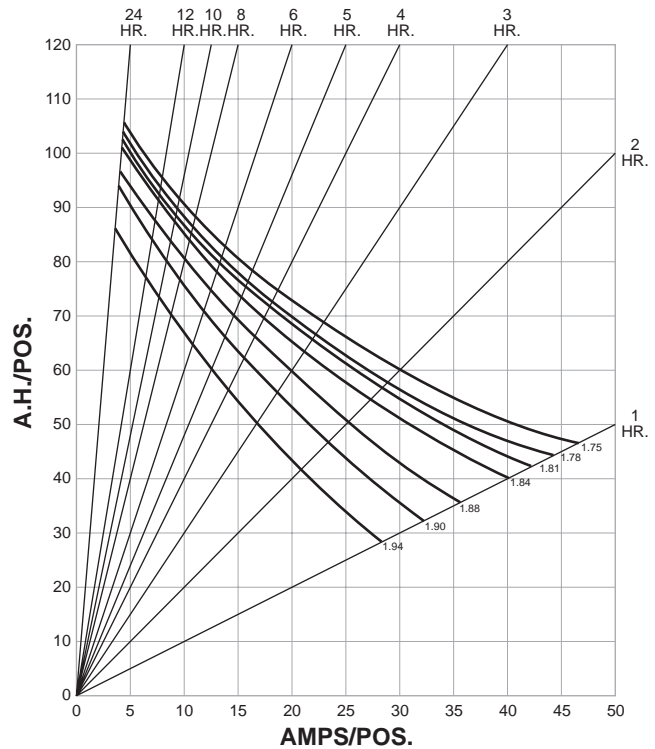

**Unigy II Cell Conductance Data  
at 77°F (25°C)**

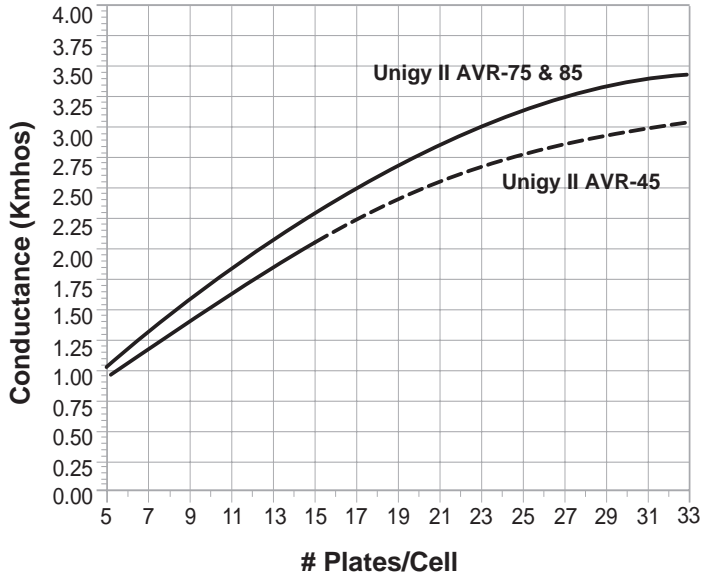

**Unigy II Cell Impedance Data  
at 77°F (25°C)**

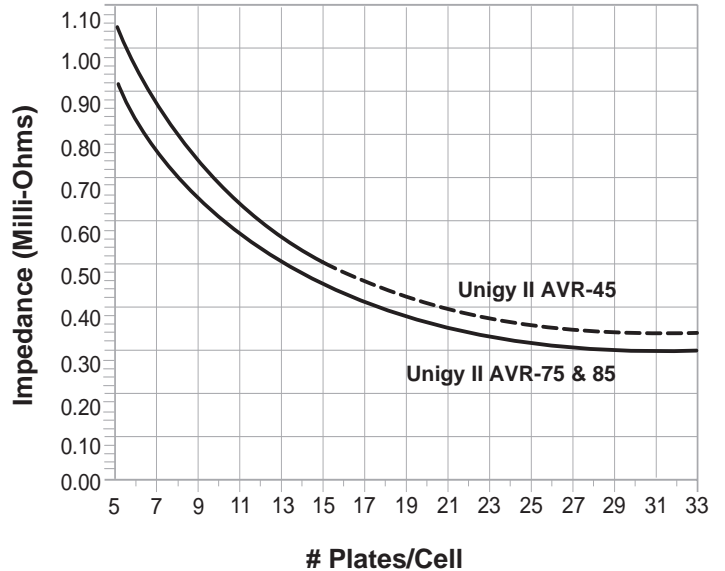

# Batteries are Recyclable!

Scrap lead-acid batteries have been safely recycled since the 1920s, and today these batteries have a higher recycling rate than other waste products such as aluminum, paper, and beverage containers made of glass or plastic, just to name a few. Over 98% of all used batteries are recycled today.

East Penn has an E. P. A.-permitted recycling system which is important for you to know because hazardous disposal laws place heavy penalties on offenders and considerable paper work burden on everyone. You can be assured that your scrap is being recycled in an environmentally safe manner with East Penn.



**T**he lead is processed, smelted, combined with reagents and alloyed into lead for use in new batteries.



**B**attery acid is recycled in a patented acid reclamation plant.

# World's Largest and Most Modern Battery Manufacturing Facility



Smelter and Refinery



Keller Technical Center



Health & Safety Center



Automotive Battery Plant A-3



Maintenance/Machine Shop



Corporate Headquarters



Plastics Molding Plant

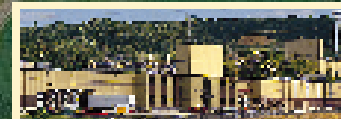

Specialty Battery Plant S-1



Industrial Battery Plant



Cable and Wire Plant

Since 1946, East Penn has been producing high quality batteries for the stationary, industrial, automotive, commercial, marine and specialty markets. A progressive company committed to the future, East Penn operates the largest single-site manufacturing facility in the industry. To keep pace with the increasing demand for our high quality products, East Penn is pursuing an aggressive expansion plan. In fact, our new high-tech facilities and computer monitoring and control systems have made us the industry's most technologically advanced battery manufacturer. All Deka batteries and accessories are produced at a huge single-site manufacturing plant, pictured above. Facilities at this 260+ acre site include a specialty battery plant, an industrial battery plant, three

automotive battery plants, wire and cable manufacturing plants, a state-of-the-art oxide facility, an acid reclamation plant, a modern technical center, an E.P.A.-Part "B" permitted lead smelter and refinery, a pilot plant, two water purification plants, a fully equipped machine shop, a fleet repair and maintenance garage, plus dozens of other support facilities. Our innovative computer-integrated manufacturing techniques, combined with more than 250 quality assurance checks, guarantee that every Deka battery meets our rigid quality and performance standards. Staffed with a stable, long-term management team, East Penn is an independent company dedicated to producing a world-class product, delivered on time when and where it's needed for complete customer satisfaction.

## ***EAST PENN manufacturing co., inc.***

Lyon Station, PA 19536-0147 • Phone: (610) 682-6361 • Fax: (610) 682-4781

**Order Department Hotline: (610) 682-4231**

WWW: <http://www.eastpenn-deka.com>

E-mail: [eastpenn@eastpenn-deka.com](mailto:eastpenn@eastpenn-deka.com)

No part of this document may be copied or reproduced, electronically or mechanically, without written permission from the company.