



Industrial 48VDC 10KVA Inverter

Series 1000 DC to AC Inverter

- True On-line Technology for Maximum Power Protection
- Pure Sine Wave Output
- Transistor Power Block Technology
- 20-Year Design Life
- Solid State Static Transfer Switch Standard
- Copper Wound Transformers
- Easy Access Front Door
- Input to Output Isolation
- Battery Noise Less than 32dBnC
- Low Audible Noise
- Short Circuit Protection
- Built to Meet UL1778, NEMA, NEC, ANSI and FCC Standards
- Mounts in Standard 19" or 23" Rack
- Handles 3:1 Crest Factor Loads
- DC Input Circuit Breaker
- AC Output Circuit Breaker
- Form "C" Alarm Interface Contacts
- Light Gray Powder Coat Finish



OPTIONS

- ⇒ Multiple Voltage Outputs Available
- ⇒ 50Hz/60Hz Models
- ⇒ Wrap-around Maintenance Bypass Switch
- ⇒ Floor Mount Kit
- ⇒ LED Display for Output Voltage and Amps
- ⇒ Direct Inverter (No Static Switch)
- ⇒ Customizable Designs for Unique Applications

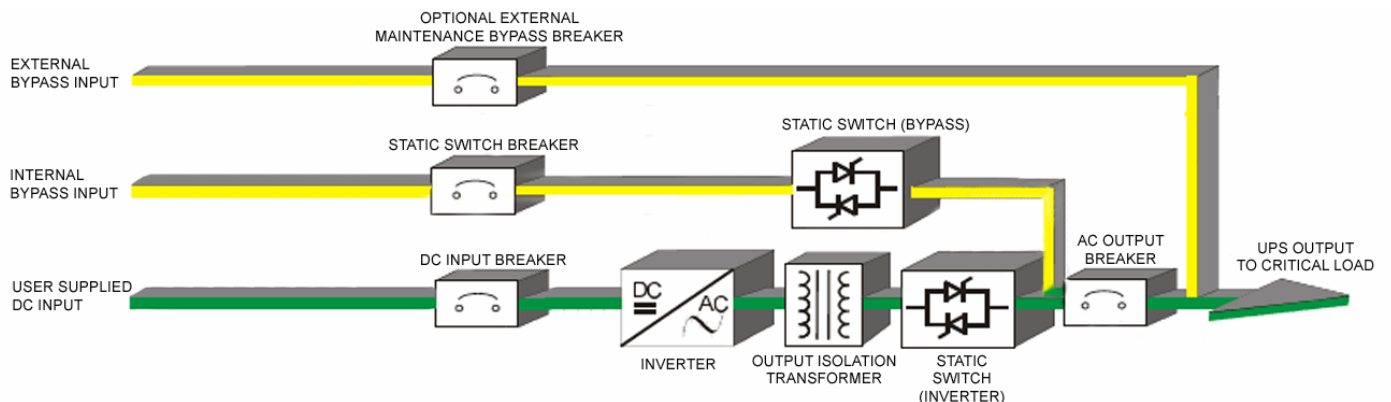



Industrial 48VDC 10KVA Inverter

Technical Specifications	
DC INPUT	
Nom. Voltage	48VDC (40 to 60 VDC)
Current	230A @ Full Load
Noise Feedback	Less than 32dBmC
Protection (Circuit Breaker)	250A
AC OUTPUT	
Power Rating	10KVA / 8KW
Nominal Voltage	120 VAC Standard, 100/127/200/208/220/230/240 Optional
Frequency	50 / 60Hz
Frequency Stability	±0.1% Internal Crystal Controlled
Acceptable Bypass Synchronization	Standard 58.8 Hz to 61.2 Hz
Regulation	±2% over entire input voltage and load range
Waveform	Sinusoidal
Crest Factor	3:1
Harmonic Distortion	< 1% with linear load from .8 leading to .8 lagging power factor
Overload	125% for 10 min, 150% for 1 min
Protection Circuitry	Circuit Breaker and Fusing
AC BYPASS INPUT	
Voltage (V)	120 VAC Standard, other voltages available as an option
Frequency (Hz)	50 / 60Hz (Bypass freq. must match output freq.)
ENVIRONMENT	
Operating Temperature	32°F to 122°F (0°C to 50°C)
Ventilation	Forced Air (front to back)
Heat Dissipation	5,118 BTU / hr.
Humidity	0 – 95% non-condensing
Audible Noise	< 55 dB(A) Scale @ 1 meter
Operational Altitude	5,000 ft. (1,500m)
DIMENSIONS	
Height (inches)	40
Width (inches)	17
Depth (inches)	18
Weight (lbs)	420
ENCLOSURE	
Color	ANSI 61 Gray
Rating	NEMA1
Cable Entry	Rear / Bottom

Note: All data is subject to change without notice.