



# Industrial Inverter Floor Mount 120VDC

## Series 1000

### DC to AC Inverter Features

- True On-line Technology for Maximum Power Protection
- True "Zero Break" Fully Rated Solid State Static Transfer Switch Standard
- Pure Sine Wave Output
- Transistor Power Block Technology
- 20-Year Design Life
- Copper Wound Transformers
- Easy Access Front Door
- Input to Output Isolation
- Battery Noise Less than 32dBnC
- Low Audible Noise
- Short Circuit Protection
- Heavy Duty Casters
- Handles 5:1 Crest Factor Loads
- DC Input Circuit Breaker
- AC Output Circuit Breaker
- Form "C" Alarm Interface Contacts
- ANSI 61 Gray Powder Coat Finish
- Built to Meet UL1778, NEMA, NEC, ANSI and FCC Standards



#### OPTIONS

- ⇒ Multiple Voltage Outputs Available
- ⇒ 50Hz/60Hz Models
- ⇒ External Maintenance Bypass Switch
- ⇒ Direct Inverter (No Static Switch)
- ⇒ Customizable Designs for Unique Applications

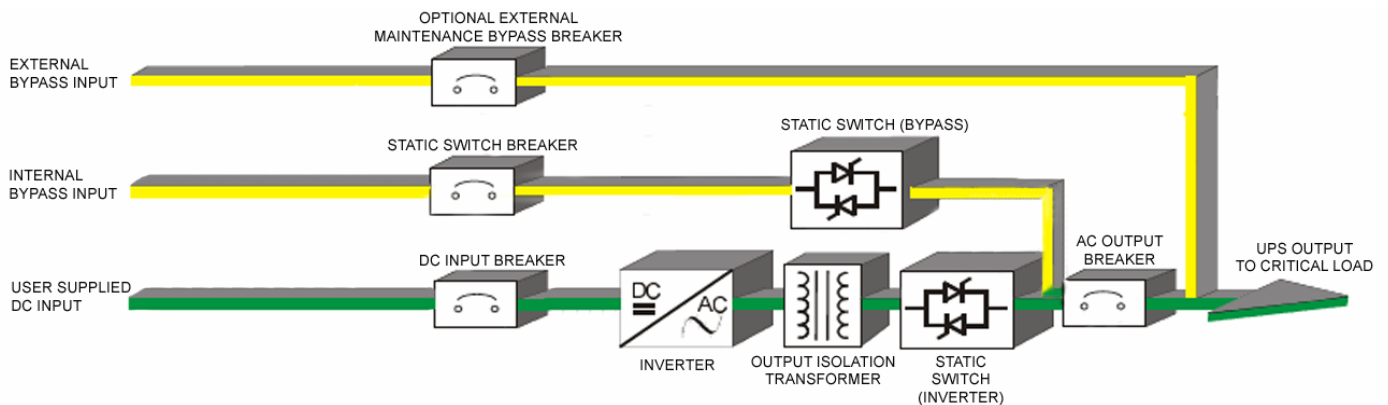



# Industrial Inverter Floor Mount 120VDC

Technical Specifications				
DC INPUT				
Model	3kva / 3kw	5kva / 5kw	7.5kva / 5kw	10kva / 10kw
Nominal DC Voltage (V)	120	120	120	120
Max Current (A)	28	46	69	92
Protection (Breaker Amps)	32	50	80	125
Noise Feedback	Less than 32dBmC			
AC OUTPUT				
Power Rating	3kva / 3kw	5kva / 5kw	7.5kva / 5kw	10kva / 10kw
Nominal Voltage	120 VAC Standard, 100/127/200/208/220/230/240 Optional			
Frequency	50 / 60Hz	50 / 60Hz	50 / 60Hz	50 / 60Hz
Frequency Stability	±0.1% Internal Crystal Controlled			
Acceptable Bypass Synchronization	Standard 58.8 Hz to 61.2 Hz			
Regulation	±2% over entire input voltage and load range			
Waveform	Pure Sine Wave			
Crest Factor	5:1			
Harmonic Distortion	< 1% with linear load from .8 leading to .8 lagging power factor			
Overload	125% for 10 min, 150% for 1 min			
Protection Circuitry	Circuit Breaker and Fusing			
AC BYPASS INPUT				
Voltage (V)	120 VAC Standard, other voltages available as an option			
Frequency (Hz)	50 / 60Hz (Bypass freq. must match output freq.)			
ENVIRONMENT				
Operating Temperature	32°F to 122°F (0°C to 50°C)			
Ventilation	Forced Air (front to back)			
Heat Dissipation (BTU/Hr)	1,535	2,559	3,839	5,118
Humidity	0 – 95% non-condensing			
Audible Noise	< 50 dB(A) Scale @ 1 meter			
Operational Altitude	5,000 ft. (1,500m)			
DIMENSIONS				
Model	3kva / 3kw	5kva / 5kw	7.5kva / 5kw	10kva / 10kw
Height (inches)	27	27	36	36
Width (inches)	13	13	16	16
Depth (inches)	31	31	31	31
Weight (lbs)	230	275	380	400
ENCLOSURE				
Color	ANSI 61 Gray			
Rating	NEMA1			
Cable Entry	Rear			

Note: All data is subject to change without notice.